

HS-700D-N Technical Data Sheet

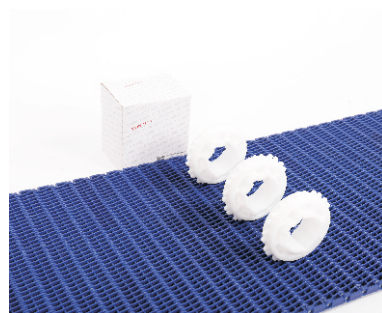
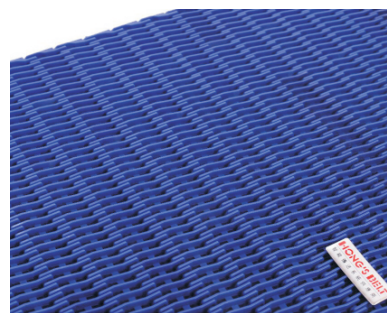
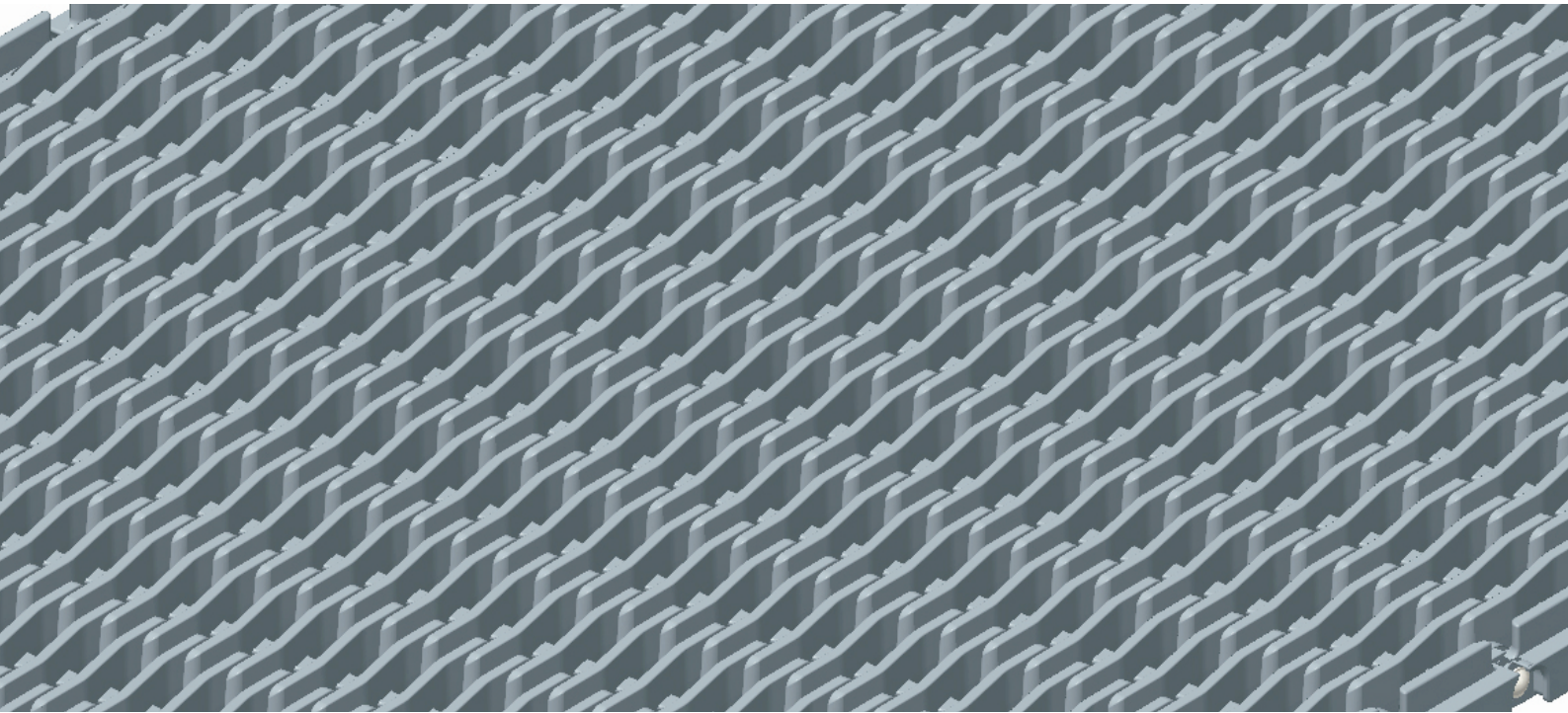
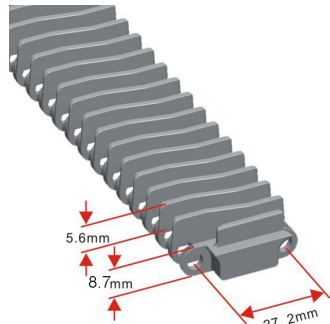

<p>Pitch: 27.2mm Minimum Width: 152mm Open Area: 38% Approved: FDA Rod: Ø 4.5mm Flight: No Side Guard: No Curve: No</p>	
--	--

Data

Belt Material	Belt Strength			Temperature		Belt Weight (Kg/M ²)
	Straight		Curve	°C (min.)	°C (max.)	
	Kg/M(BW)	N/M(BW)				
Polypropylene	1320	13200	--	1	100	5.2
Polyethylene	1060	10600	--	-60	60	5.6
Acetal	1880	18800	--	-40	80	8.2
Nylon	1610	16100	--	1	180	7.8

BW – Belt Width

Color Table

Polypropylene					Polyethylene					Acetal					Nylon				
W	G	N	DB	B	W	G	N	DB	B	W	G	N	DB	B	W	G	N	DB	B
●	●			●			●			●						●			

W-White, G-Gray, N-Nature, DB-Dark brown, B-Blue (For more information of belt color, pls consult our sales team)

Friction Table

Belt Material	Friction Wear strips & Products							
	UHMW	HDPE	Steel	Glass	SUS	Plastic	Cardboard	Aluminum
Polypropylene	0.32	0.24	0.15	0.09	0.13	0.08	0.15	0.25
Polyethylene	0.13	0.11	0.26	0.19	0.31	0.16	0.21	0.41
Acetal	0.11	0.09	0.27	0.16	0.26	0.15	0.19	0.28
Nylon	0.18	0.13	0.25	0.16	0.26	0.16	0.19	0.27

SUS – Stainless Steel

Equivalent type with other Brand

Brand Name	Intralox	Habasit	UNI	Rexnord	MCC	ScanBelt
Series & Type	S900 Raised Rib	--	--	--	--	--

The above content is only for reference.

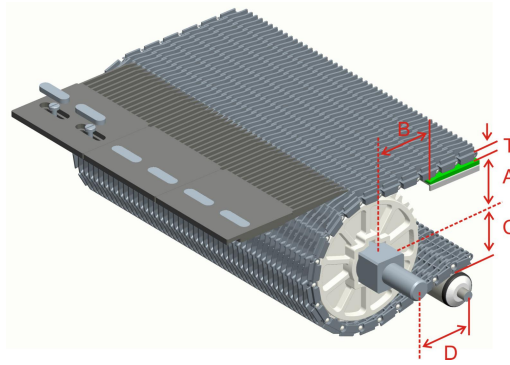

Conveyor Frame Dimensions

Unit : mm

No. Teeth	A (Min.)	B (Min.)	C (Max.)	D (Min.)	T	T1
6	21.8	36.15	21.45	200	8.7	5.6
9	35.55	49.9	35.2	200		
10	39.4	53.75	39.05	250		
12	48.4	62.75	48.05	250		
17	71.65	86	71.3	300		
18	74.55	88.9	74.2	300		
20 / 20-Split	83.15	97.5	82.8	300		
24	100.55	114.9	100.2	300		

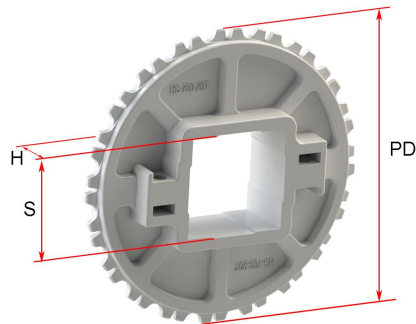
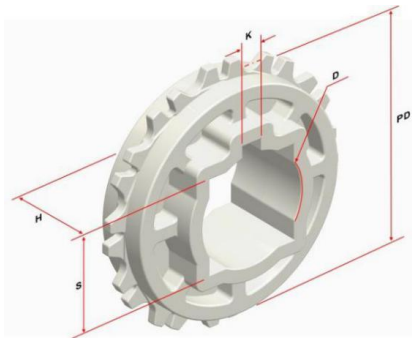

Sprocket Dimensions

Unit: mm

No. Teeth	PD	OD	S	D	H	K
6	54.40	52.3	25.4	--	18.5	--
9	79.53	79.8	25.4/38.1/40	25.4	21.5	6.35X3.17
10	88.02	87.5	25.4/38.1/40	25.4/30	18.8	6.35X3.17
12	105.09	105.5	25.4/30/38.1/40	25.4/30/31.75/35/38.1/45/47/50	35	6.35X3.17
17	148.03	152	--	114	35	4.5X4.5
18	156.64	157.8	38.1/40/50/60/63.5	25.4/30/31.75/35/38.1/40/46/47	35	6.35X3.17
20	173.87	175	38.1/40/60	25.4/30/31.75/38.1	35	6.35X3.17
20-Split	173.87	175	60	31.75/30	40	6.35X3.17
24	208.39	209.8	38.1/40	25.4/30/38.1/45	35	8X8

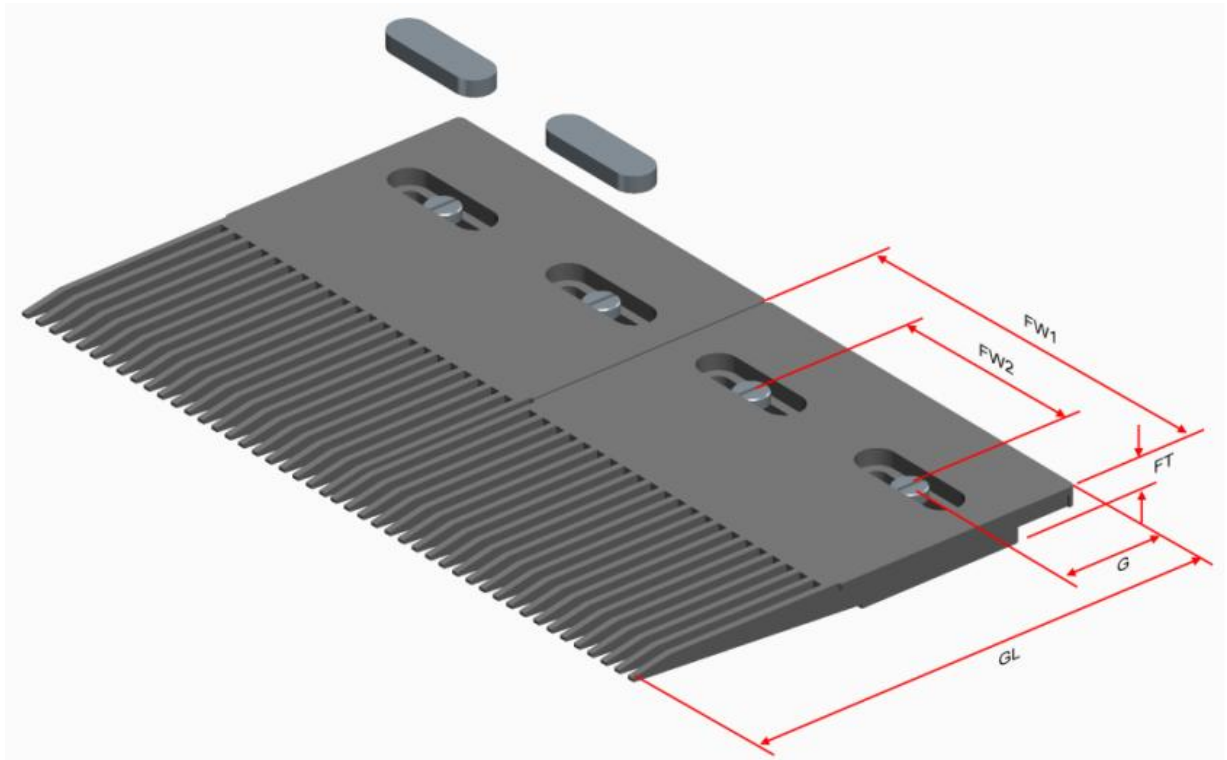
**Finger Transfer Plate Frame Dimensions**

Unit: mm

No. Finger	FW1	FW2	FT	G	GL
18	147.3	77	6.7	51	163.2